

TWO DISC CLUTCH for KART RACING ENGINES



PATENTS
6,279,711
6,536,574
New 9,151,346

IMPORTANT - The Vortex THREADS clutch is designed to rotate in only one direction. The sprocket is attached to the drum with a left-hand thread and must be run inboard (sprocket adjacent to engine block) to prevent clutch damage.

Performance Notes - The Vortex clutch was designed to engage very smoothly in order to avoid "bogging" the engine.

Assembly -

1. Check the engine's crankshaft for smoothness and cleanliness. Remove all dirt, rust and burrs.
2. Install the short spacer with the chamfered edge of the spacer against the chamfer on the crankshaft.
3. If using a large sprocket, mount the sprocket followed by the long spacer. If using a small sprocket, mount the long spacer followed by the sprocket.
4. Install the clutch assembly and key followed by the end cap.
5. Install the hex head cap screw and torque to 460 inch pounds if threads are clean and dry, 270 inch pounds if the threads are coated with an anti-seize compound.
6. **DO NOT USE AN IMPACT WRENCH.**

Adjustment - Set the engagement speed to the engine's peak torque RPM. The engagement speed is set by spring stiffness (Silver, Black, Gold) and the position (1 thru 5) of the lower spring leg. The optional Vortex Spring Wrench, Part Number 4018 simplifies spring removal and replacement. See *Spring Chart for Estimated Engagement RPM*.

Maintenance - Clutches like tires get dirty quickly. It is important to clean clutch discs every race weekend if not every heat if you want maximum acceleration. **Use anti-seize compound on sprocket and drum connection.**

Upon disassembly use an appropriate marker to identify the top sides of the drive plates and clutch discs if they will be reused. It is very important to replace each disc and drive plate in its original orientation. Heat and pressure force the drive plates into a permanently cupped shape and the soft discs will quickly wear into a conforming shape. These five pieces become a matched set. An upside down clutch disc or drive plate can cause poor contact between members and require another break-in process. Even if only one of these five parts is damaged, replace all five parts for maximum performance.

The Vortex clutch is not sensitive to air gap. Clutch disc thickness and taper do not affect performance. The criteria for replacing a disc are heat and chemistry i.e. replace the discs when they become glazed.

SMC highly recommends cleaning clutch (friction) discs mechanically NOT chemically. Brake cleaner and other chemicals are inadequate for removing dirt and other fine particles packed into the tiny voids. Do not use sandpaper on the 12 tab disc. A stainless steel utility brush (aka platers' brush) with a wire diameter of .006 is ideal for removing the hard-to-get-at dirt. The friction material is very porous and unfortunately works well as a dirt collector. Once the voids are filled and packed, the dirt starts to act as a lubricant (think tiny ball bearings) and causes the clutch to slip for a greater distance.

Drive plates that are tan, yellow, light blue or dark blue in very small areas and distorted less than 0.020 inch from flat may be reused. Heat and pressure cause friction material to separate from the clutch disc and bond to the drive plates. This friction material should be removed from the drive plates with sandpaper.

Use a Torx® T25 wrench with 60 inch-pounds (5 foot-pounds) of torque to tighten the six button head cap screws.

SMC Roller Levers cause disc clutches to engage more effectively. Rollers located at the contact point between the lever and the pressure plate eliminate sliding friction. The lower friction reduces engine bogging. There is now more energy available for acceleration.

Protect the clutch from moisture. Corrosion will diminish performance.

Additional information is available at the SMC web site www.kartclutches.com

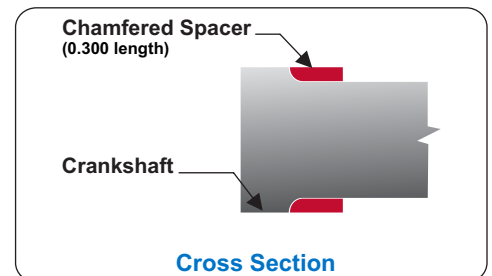
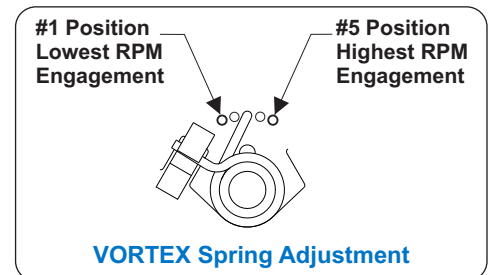

TWO DISC CLUTCH for KART RACING ENGINES

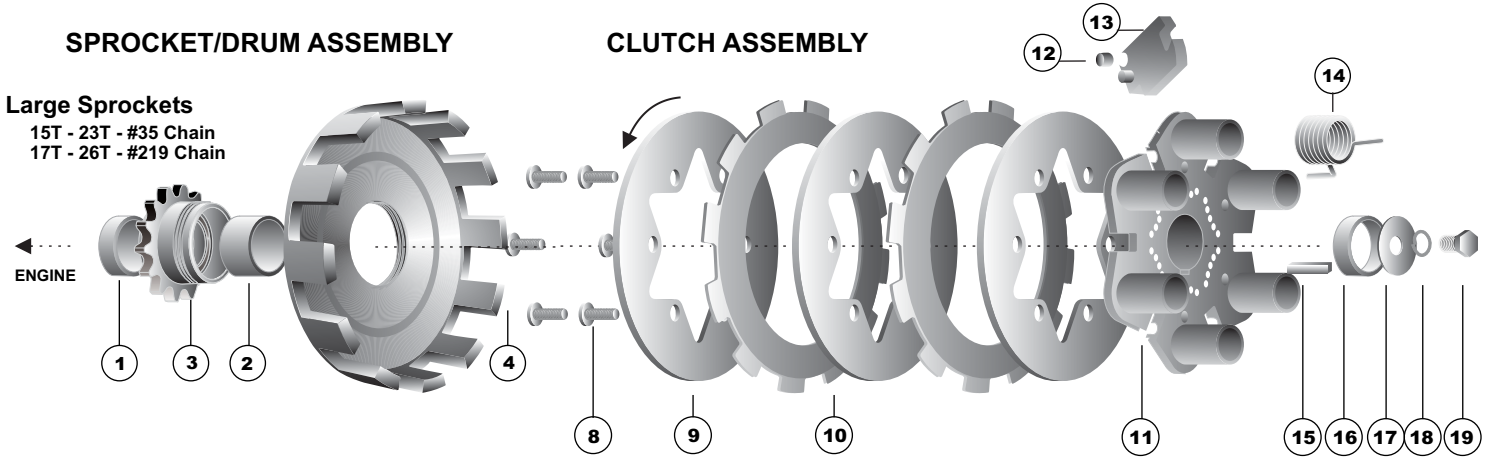

PARTS

Ref. No.	Part No.	Price Each	Description (Number Required)
	4202	330.00	VORTEX RED, Two Disc Clutch, No Sprocket
1	4212	4.00	Chamfered Spacer (0.300 length)
2	4213	4.00	Spacer (0.575 length)
3	xxxx		SMC Sprocket (See Sprocket Chart)
4	4232	29.95	Drum, 12-Slots, Two Disc
8	4006	0.25	Button Head Cap Screw (6)
9	4003	16.00	Drive Plate (3)
10	4250	25.75	Clutch Disc, Twelve Tabs (2)
11	4242	135.00	Drive Hub, Two Disc
12	4279	3.00	Roller, Vortex (For Lever #4280) (6)
13	4280	20.00	SMC Roller Lever, New, Vortex (6)
14	4059	3.00	VORTEX Spring, Black (6) (See Spring Chart)
15	4036	0.50	Key, (0.875 length)
16	4032	4.00	Spacer (0.250 length)
17	4227	2.00	Crankshaft Washer
18	4025	0.06	Grade 8 Lock Washer
19	4217	0.35	Hex Head Cap Screw
	4234	95.00	Rebuild Kit, (3 drive plates, 2 discs, 6 screws)

OPTIONAL PARTS

Ref. No.	Part No.	Price Each	Description (Number Required)
9T & 10T #35 Chain, 11T & 12T #219 Chain Sprockets:			
1	4206	4.00	Chamfered Spacer (1.125 length)
4	4236 *	29.95	Drum, 12-Slots, Two Disc, R.H.
16	4205	0.75	Socket Head Cap Screw
11T #35 Chain, 13T & 14T #219 Chain Sprockets:			
2	4210	4.00	Spacer (0.813 O.D. x 0.575 length)
	4234	90.00	Rebuild Kit, TwoDisc Clutches (3 drive plates, 2 12-T clutch disc, 6 cap screws)

TOOLS

Part No.	Price Each	Description (Number Required)
4218	20.00	SMC Sprocket Wrench
4018	15.00	VORTEX Spring Wrench
4055	9.00	T-Handle, T25 Torx (Tool for #4006)

TWO DISC CLUTCH for KART RACING ENGINES



PATENTS
6,279,711
6,536,574
New 9,151,346

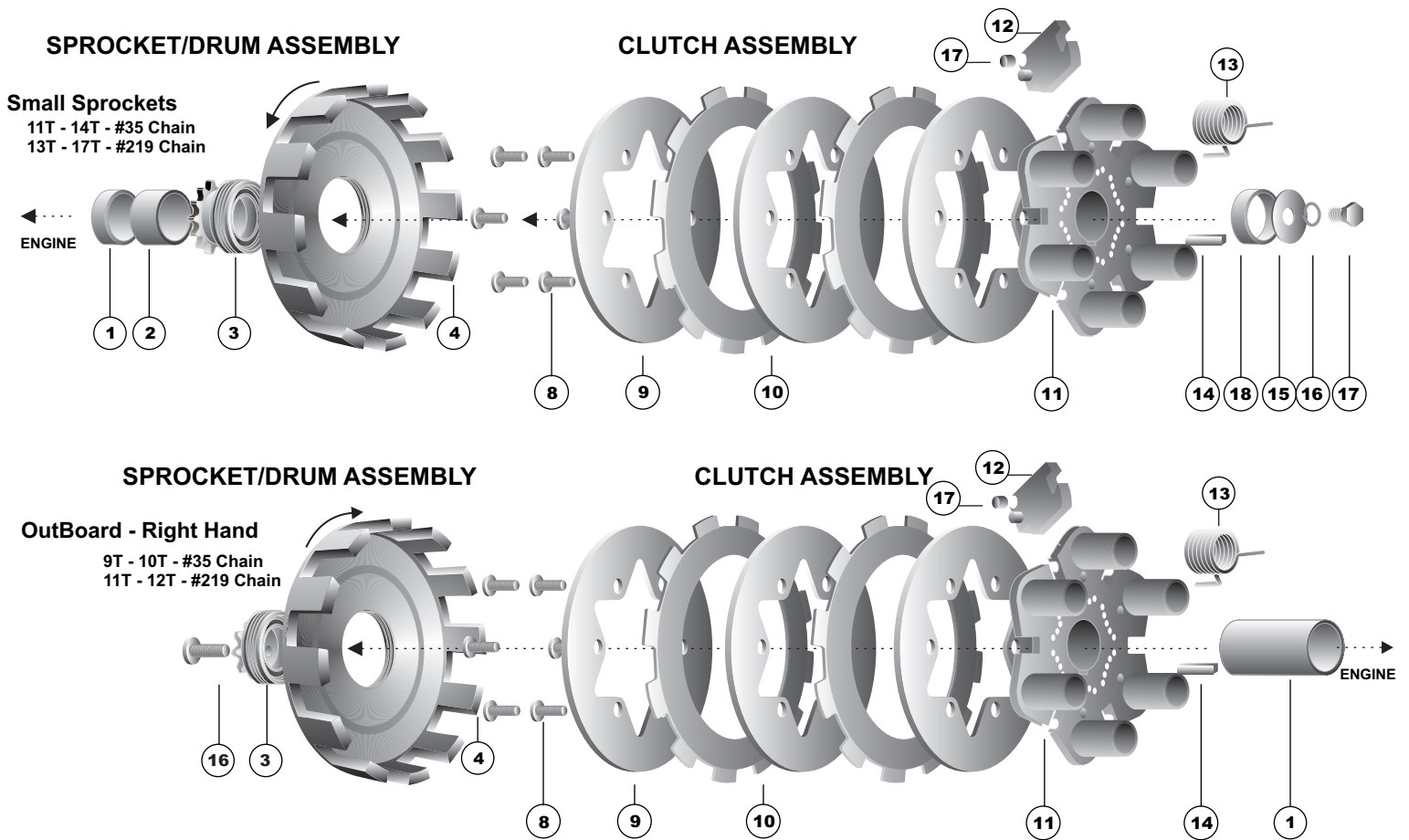

Spring Chart - Estimated Engagement RPM

Engine	Silver 1	Silver 2	Silver 3	Silver 4	Silver 5	Black 1	Black 2	Black 3	Black 4	Black 5	Gold 1	Gold 2	Gold 3	Gold 4	Gold 5
Honda/clone, Stock	3000	3160	3320	3480	3640	3600	3825	4050	4275	4500	4200	4425	4650	4875	5100
Honda/clone, Restricted	3100	3260	3420	3580	3740	3700	3925	4150	4375	4600					
Honda/clone, Modified	3200	3360	3520	3680	3840	3800	4025	4250	4475	4700	4400	4625	4850	5075	5300
B & S Animal, Stock	3200	3360	3520	3680	3840	3800	4025	4250	4475	4700	4400	4625	4850	5075	5300
B & S Animal, Restricted	3300	3460	3620	3780	3940	3900	4125	4350	4575	4800					
B & S Animal, Modified	3400	3560	3720	3880	4040	4000	4225	4450	4675	4900	4600	4825	5050	5275	5500
B & S flat head	3400	3560	3720	3880	4040	3600	3825	4050	4275	4500	4600	4825	5050	5275	5500
B & S flat head, Restricted	3500	3660	3820	3980	4140	3700	3925	4150	4375	4600					

If you plot the engine's torque vs. rpm curve and the clutch's torque vs. rpm curve on the same graph, the two lines will cross. At that point the clutch and engine are in equilibrium. The equilibrium point defines the engagement rpm. At lower rpm the clutch slips because the engine produces more torque than the clutch can accommodate. At higher rpm the clutch is locked up because it can handle much more torque than the engine can produce. If you modify the engine by changing cam, jets, bore, stroke, valve position, fuel type et cetera, the shape of the engine's torque vs. rpm curve will change. If you modify the clutch by changing spring position, the shape of the clutch's torque vs. rpm curve will change. When either curve changes shape, the equilibrium point moves. The table is merely an estimate of where that point occurs for various combinations of engines and springs.

See Spring Chart for Estimated Engagement RPM.



#35 SPROCKET CHART

		Part No.	Price Each	Description
#219 CHAIN	PTO Assembly	4659 *	24.00	9T Sprocket Assembly
		4660 *	24.00	10T Sprocket Assembly
		4661	24.00	11T Sprocket Assembly
		4662	24.00	12T Sprocket Assembly
		4663	24.00	13T Sprocket Assembly
		4664	24.00	14T Sprocket Assembly
		4665	24.00	15T Sprocket Assembly
		4666	24.00	16T Sprocket Assembly
		4667	24.00	17T Sprocket Assembly
		4668	24.00	18T Sprocket Assembly
		4669	24.00	19T Sprocket Assembly
		4670	27.45	20T Sprocket Assembly
		4671	27.45	21T Sprocket Assembly
		4672	27.45	22T Sprocket Assembly
		4673	27.45	23T Sprocket Assembly

#219 SPROCKET CHART

		Part No.	Price Each	Description
#219 CHAIN	PTO Assembly	4761 *	24.00	11T Sprocket Assembly
		4762 *	24.00	12T Sprocket Assembly
		4763	24.00	13T Sprocket Assembly
		4764	24.00	14T Sprocket Assembly
		4765	24.00	15T Sprocket Assembly
		4766	24.00	16T Sprocket Assembly
		4767	24.00	17T Sprocket Assembly
		4768	24.00	18T Sprocket Assembly
		4769	24.00	19T Sprocket Assembly
		4770	24.00	20T Sprocket Assembly
		4771	24.00	21T Sprocket Assembly
		4772	24.00	22T Sprocket Assembly
		4773	24.00	23T Sprocket Assembly
		4774	27.45	24T Sprocket Assembly
		4775	27.45	25T Sprocket Assembly
		4776	27.45	26T Sprocket Assembly
		4778	267.45	28T Sprocket Assembly

#428 SPROCKET CHART

		Part No.	Price Each	Description
#428 CHAIN	PTO Assembly	4562	46.00	12T Sprocket Assembly
		4563	46.00	13T Sprocket Assembly
		4564	46.00	14T Sprocket Assembly

PULLEY CHART

		Part No.	Price Each	Description
8MM PULLEY	PTO Assembly	4523	76.00	23t-8mm20m HTD Pulley
		4524	76.00	24t-8mm20m HTD Pulley
		4525	76.00	25t-8mm20m HTD Pulley
		4526	76.00	26t-8mm20m HTD Pulley
		4527	76.00	27t-8mm20m HTD Pulley
		4528	76.00	28t-8mm20m HTD Pulley
		4529	76.00	29t-8mm20m HTD Pulley
		4530	76.00	30t-8mm20m HTD Pulley
		4532	76.00	32t-8mm20m HTD Pulley

- NOTES: 1. Sprockets include Ball Bearing and Retaining Rings
 2. * Right Hand Thread
 3. Additional Sprockets, limited supply available in: #420, #40